



INTELLIGENT CONTACTLESS LOCKING SYSTEM.
MINIMAL, SEAMLESS, DESIGN.

NL1® INTEGRA



INTELLIGENT LOCKING SYSTEMS



INTELLIGENT CONTACTLESS LOCKING SYSTEM.
MINIMAL, SEAMLESS, DESIGN.

NL1®INTEGRA

MAIN FEATURES

- ✓ Fully integrated in the locker.
- ✓ Automatic and emergency openings.
- ✓ Encrypted communications.
- ✓ Electronic components, batteries and mechanical locking system are protected inside the lock.
- ✓ SDK ready to be integrated with third parties.



TECHNICAL SPECIFICATIONS

Authentication method	> RFID
Supported technologies	> MIFARE® (Classic1K/4K 4B and 7B UID – ISO/IEC 14443)
Type of Reading	> Sector
Reading Distance	> Up to 20 mm (including door thickness)
Free Mode	> Up to 3 locks simultaneously with a user card
Fixed Mode (dedicated)	> Up to 6 locks with a user card (more than 1 user card per fixed lock)
Multifunction mode	> Up to 3 free locks and 1 fixed lock simultaneously with a user card
Notifications	> Buzzer
Alarms	> Low battery warning (does not allow the locker to be closed)
Communication standard	> NFC
Type of Encryption	> AES 256
Maximum number of connections	> 1
Batteries (Type and amount)	> 4 alkaline batteries VARTA Type AA
Battery Life	> Minimum 2 years (depending on use and configuration)
Dimensions	> 109.5 mm x 129.5 mm x 30 mm
Weight	> 370 g
Closing resistance	> 900 N
Outer Finish	> Satin Grey (RAL7035)
Temperature	> From -10 °C to 42 °C (indoor and non-condensing)
Protection	> IK09

OTHER DATA

Door Material	> Phenolic > Glass > HPL laminate > Melanin
Door Thickness	> < 20 mm
Availability	> Right / Left

ACCESSORIES

- > Ojmar NFC portable programmer
- > SW Spherio
- > Desktop card reader
- > SDK for integrators
- > Infoterminal (optional)
- > Magnetic door lock (optional)
- > Ojmar locking system (optional)
- > Outer sticker (optional)

ASSEMBLY

RIGHT HAND

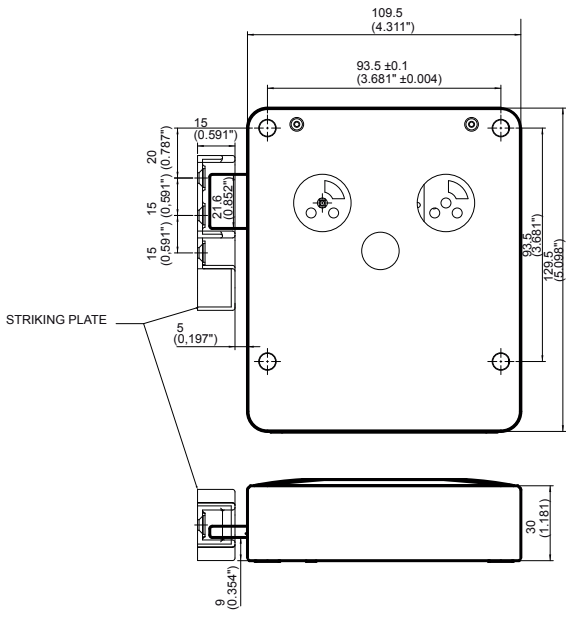

STRIKING PLATE

LEFT HAND

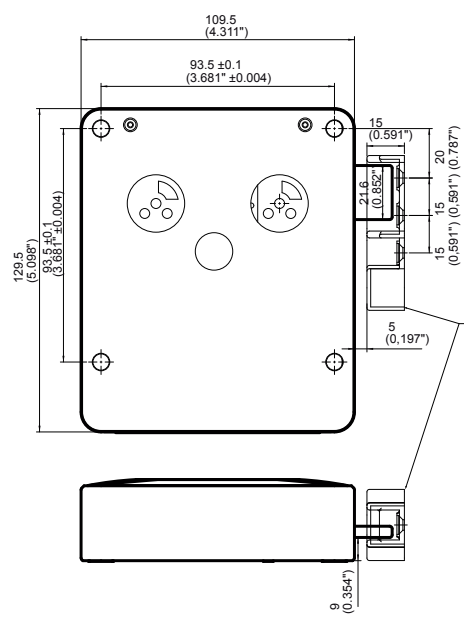

STRIKING PLATE

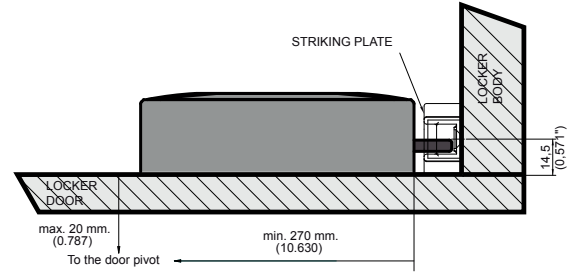
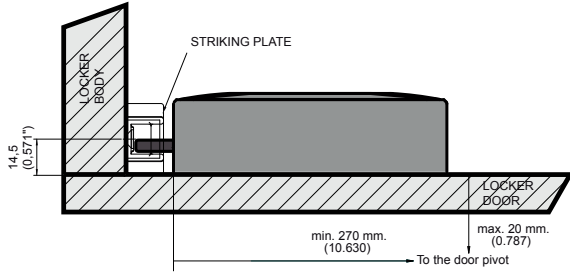

RFID DATA IDENTIFICATION

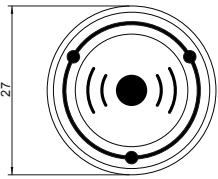

PUSH BUTTON

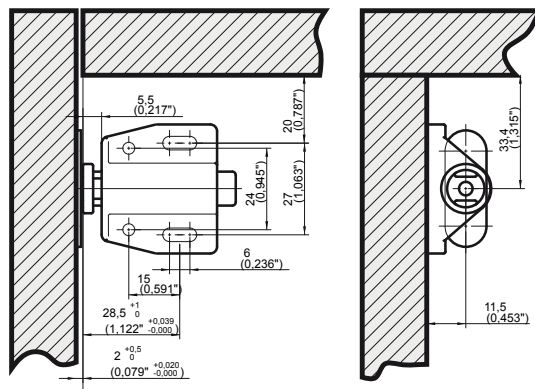

OJMAR'S STRIKING PLATE

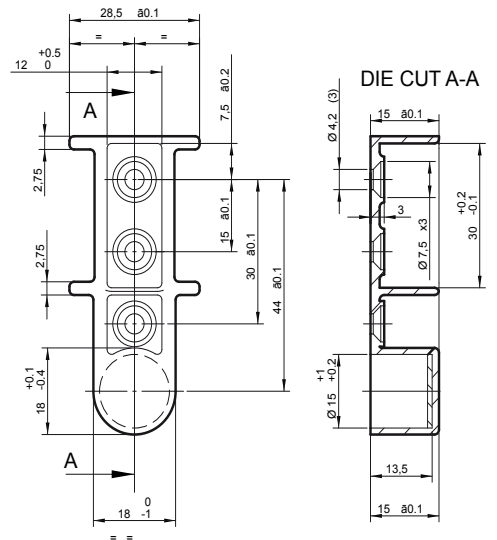



INTELLIGENT LOCKING SYSTEMS

CONTACT
sales@ojmar.com
+34.943.748.484

OJMAR HQ
Polígono Industrial de Lerun
20870 Elgoibar - SPAIN

OJMAR USA
17155 Von Karman Ave, S111
Irvine CA. 92614 - USA

www.ojmar.com



INTEGRA V1